

# OIL-X Die-cast Aluminium Compressed Air Filters

Grade WS

Water Separators / Liquid Separators (1/4" ~ 4")



## Water Separators /Liquid Separators

Untreated compressed air contains a minimum of 10 contaminants that must be treated for the system to operate safely, efficiently & cost effectively. Liquid water (and to a lesser extent, liquid oil) exist in all compressed air systems. Often these two liquids combine to make an aggressive, oily, acidic sludge, all of which causes problems such as corrosion of piping, permanent damage to valves, cylinders, pneumatic tools, machinery and reducing the effectiveness of aftercoolers and heat exchangers. Liquids are typically the first of 10 contaminants to be treated.

Parker OIL-X Grade WS high efficiency water separators have been designed for use with compressor inter coolers / after coolers, integration with refrigeration dryer heat exchangers or protection of coalescing filter from heavy liquid contamination.

Traditional centrifugal water separators are designed for maximum separation efficiency at maximum flow rate, with separation efficiency falling off as flow rates vary (especially with variable speed compressors). As separators rarely operate at 100% of rated flow all the time, the Parker OIL-X Grade WS high efficiency water separators were designed with variable speed compressors in mind and provide >92% liquid separation from compressed air between 25% & 100% of their rated flow.

Parker OIL-X Grade WS water separators have also been designed with the perfect balance between air quality and energy efficiency to provide maximum separation efficiency with minimal operational costs.



## Advantages

- Meets the requirements for air quality (liquids) shown in all editions of ISO8573-1, the international standard for compressed air quality
- Specifically designed to meet the needs of modern air compressors and optimised for use with variable speed air compressors
- Flow management system - Engineered to provide smooth air flow from entry to exit
- Water separator module design includes optimised vanes to spin the compressed air, a high efficiency impinger for maximum separation efficiency, vortex concentrator and 90-degree elbow with turning vanes to promote a consistent, optimum air flow with minimal pressure loss
- Parker OIL-X Grade WS Water Separators are fully tested – In accordance with ISO12500-4 & ISO8573-9 for liquid water
- Separation performance independently validated - by Lloyds Register
- Housing Guarantee - 10 year guarantee on filter housings
- Parker OIL-X materials of construction are FDA Title 21 CFR compliant & EX1935/2004 exempt



ENGINEERING YOUR SUCCESS.

## Separation Performance

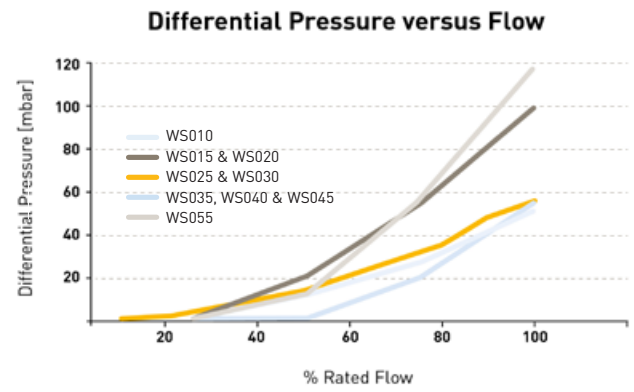
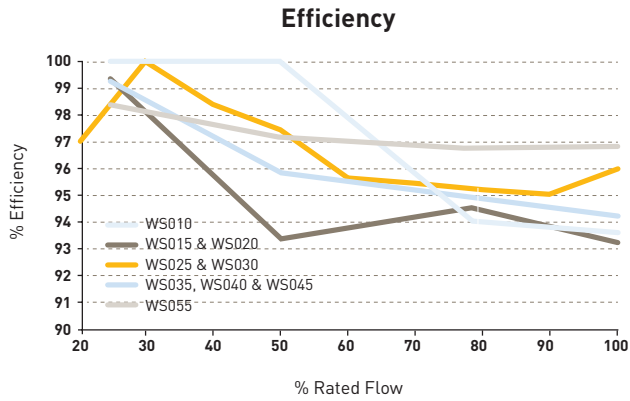

### Liquid Reduction % versus Flow

### Differential Pressure versus Flow

## Technical Data

Filtration Grade	Water Separator Models	Min Operating Pressure		Max Operating Pressure		Min Operating Temperature		Max Operating Temperature	
		bar g	psi g	bar g	psi g	°C	°F	°C	°F
WS	P010A <input type="checkbox"/> FX - P055J <input type="checkbox"/> FX	1	15	16	232	2	35	80	176
WS	P060K <input type="checkbox"/> FX	1	15	16	232	2	35	66	150

## Flow Rates

Model	Pipe Size	L/S	m³/min	m³/hr	cfm
WSP010A <input type="checkbox"/> FX	¼"	10	0.6	36	21
WSP010B <input type="checkbox"/> FX	⅜"	10	0.6	36	21
WSP010C <input type="checkbox"/> FX	½"	10	0.6	36	21
WSP015C <input type="checkbox"/> FX	½"	40	2.4	144	85
WSP020D <input type="checkbox"/> FX	¾"	40	2.4	144	85
WSP025D <input type="checkbox"/> FX	¾"	110	6.6	396	233
WSP025E <input type="checkbox"/> FX	1"	110	6.6	396	233
WSP030G <input type="checkbox"/> FX	1 ½"	110	6.6	396	233
WSP035G <input type="checkbox"/> FX	1 ½"	350	21	1260	742
WSP040H <input type="checkbox"/> FX	2"	350	21	1260	742
WSP045I <input type="checkbox"/> FX	2 ½"	350	21	1260	742
WSP050I <input type="checkbox"/> FX	2 ½"	800	48	2880	1695
WSP055J <input type="checkbox"/> FX	3"	800	48	2880	1695
WSP060K <input type="checkbox"/> FX	4"	1000	60	3600	2119

Stated flows are for operation at 7 bar (g) (102 psi g) with reference to 20°C, 1 bar (a), 0% relative water vapour pressure. For flows at other pressures, apply the correction factors shown below.

## Product Selection & Correction Factors

To correctly select a separator model, the flow rate of the separator must be adjusted for the minimum operating (inlet) pressure at the point of installation.

1. Obtain the minimum operating (inlet) pressure and maximum compressed air flow rate at the inlet of the filter.
2. Select the correction factor for minimum inlet pressure from the CFMIP table (always round down e.g. for 5.3 bar, use 5 bar correction factor)
3. Calculate the minimum filtration capacity. Minimum Filtration Capacity = Compressed Air Flow Rate x CFP
4. Using the minimum filtration capacity, select a filter model from the flow rate tables above (filter selected must have a flow rate equal to or greater than the minimum filtration capacity).

### CFMIP - Correction Factor Minimum Inlet Pressure

Minimum Inlet Pressure	bar g	1	2	3	4	5	6	7	8	9	10	11	12	13	14	15	16
	psi g	15	29	44	58	73	87	100	116	131	145	160	174	189	203	218	232
<b>Correction Factor</b>		4.00	2.63	2.00	1.59	1.33	1.14	1.00	0.94	0.89	0.85	0.82	0.79	0.76	0.73	0.71	0.68

## Separator coding example

Grade	Model	Pipe Size	Thread	Drain Option	Incident Monitor Option
WS	P & 3 digit code denotes filter housing size	Letter denotes pipe size	G = BSPP N = NPT	F = Float	I = Indicator X = None
<b>Example code</b>					
WS	P010	A	G	F	X

## Liquid Separators Tested In Accordance With

<b>Filtration Grade</b>	<b>WS</b>
<b>Filter Type</b>	Liquid Separator
<b>Test Methods Used</b>	ISO8573-9 ISO12500-4
<b>ISO12500-4 Inlet Challenge Concentration</b>	33 ml of liquid water per cubic metre of compressed air

## Weight & Dimensions

Model	Height (H)		Width (W)		Depth (D)		Weight	
	mm	ins	mm	ins	mm	ins	kg	lbs
010A	180	7.09	76	2.99	65	2.56	0.84	1.86
010B	180	7.09	76	2.99	65	2.56	0.84	1.84
010C	180	7.09	76	2.99	65	2.56	0.82	1.81
015C	238	9.37	89	3.5	84	3.31	1.16	2.55
020D	238	9.37	89	3.5	84	3.31	1.44	3.19
025D	277	10.9	120	4.72	115	4.53	2.14	4.71
025E	277	10.9	120	4.72	115	4.53	2.69	5.92
030G	367	14.45	120	4.72	115	4.53	3.04	6.70
035G	440	20.9	164	6.46	157	6.18	6.90	15.21
040H	532	24.5	164	6.46	157	6.18	7.30	16.09
045I	532	24.5	164	6.46	157	6.18	7.10	15.65
050I	654	29.3	192	7.56	183	7.20	10.30	22.71
055J	844	36.8	192	7.56	183	7.20	15.30	33.73
060K	847	33.3	420	16.54	282	11.10	44.50	98.11

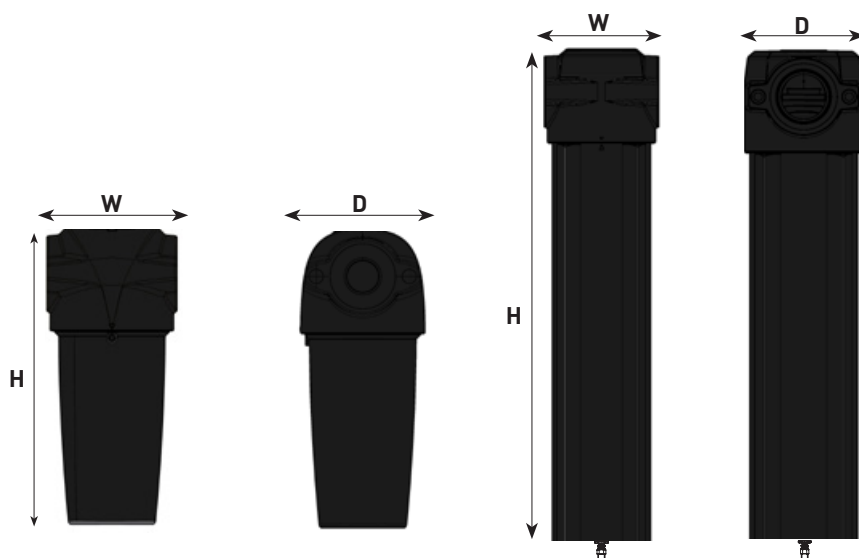

## Quality Assurance / IP Rating / Pressure Vessel Approvals

<b>Development / Manufacture</b>	ISO 9001 / ISO 14001
<b>Ingress Protection Rating</b>	Not Applicable
<b>EU</b>	Pressure vessel approved for fluid group 2 in accordance with the Pressure Equipment Directive 2014/68/EU
<b>USA</b>	Approval to ASME VIII Div. 1 not required
<b>AUS</b>	Approval to AS1210 not required
<b>GUS</b>	TR (formerly GOST-R)
<b>For use with Compressed Air Only</b>	

# Parker Worldwide

## Europe, Middle East, Africa

**AE – United Arab Emirates,**  
Dubai

Tel: +971 4 8127100  
parker.me@parker.com

**AT – Austria,** St. Florian  
Tel: +43 (0)7224 66201  
parker.austria@parker.com

**AZ – Azerbaijan,** Baku  
Tel: +994 50 2233 458  
parker.azerbaijan@parker.com

**BE/NL/LU – Benelux,**  
Hendrik Ido Ambacht  
Tel: +31 (0)541 585 000  
parker.nl@parker.com

**BG – Bulgaria,** Sofia  
Tel: +359 2 980 1344  
parker.bulgaria@parker.com

**BY – Belarus,** Minsk  
Tel: +48 (0)22 573 24 00  
parker.poland@parker.com

**CH – Switzerland,** Etoy  
Tel: +41 (0)21 821 87 00  
parker.switzerland@parker.com

**CZ – Czech Republic,** Klecany  
Tel: +420 284 083 111  
parker.czechrepublic@parker.com

**DE – Germany,** Kaarst  
Tel: +49 (0)2131 4016 0  
parker.germany@parker.com

**DK – Denmark,** Ballerup  
Tel: +45 43 56 04 00  
parker.denmark@parker.com

**ES – Spain,** Madrid  
Tel: +34 902 330 001  
parker.spain@parker.com

**FI – Finland,** Vantaa  
Tel: +358 (0)20 753 2500  
parker.finland@parker.com

**FR – France,** Contamine s/Arve  
Tel: +33 (0)4 50 25 80 25  
parker.france@parker.com

**GR – Greece,** Piraeus  
Tel: +30 210 933 6450  
parker.greece@parker.com

**HU – Hungary,** Budaörs  
Tel: +36 23 885 470  
parker.hungary@parker.com

**IE – Ireland,** Dublin  
Tel: +353 (0)1 466 6370  
parker.ireland@parker.com

**IL – Israel**  
Tel: +39 02 45 19 21  
parker.israel@parker.com

**IT – Italy,** Corsico (MI)  
Tel: +39 02 45 19 21  
parker.italy@parker.com

**KZ – Kazakhstan,** Almaty  
Tel: +7 7273 561 000  
parker.easteurope@parker.com

**NO – Norway,** Asker  
Tel: +47 66 75 34 00  
parker.norway@parker.com

**PL – Poland,** Warsaw  
Tel: +48 (0)22 573 24 00  
parker.poland@parker.com

**PT – Portugal**  
Tel: +351 22 999 7360  
parker.portugal@parker.com

**RO – Romania,** Bucharest  
Tel: +40 21 252 1382  
parker.romania@parker.com

**RU – Russia,** Moscow  
Tel: +7 495 645-2156  
parker.russia@parker.com

**SE – Sweden,** Spånga  
Tel: +46 (0)8 59 79 50 00  
parker.sweden@parker.com

**SK – Slovakia,** Banská Bystrica  
Tel: +421 484 162 252  
parker.slovakia@parker.com

**SL – Slovenia,** Novo Mesto  
Tel: +386 7 337 6650  
parker.slovenia@parker.com

**TR – Turkey,** Istanbul  
Tel: +90 216 4997081  
parker.turkey@parker.com

**UA – Ukraine,** Kiev  
Tel: +48 (0)22 573 24 00  
parker.poland@parker.com

**UK – United Kingdom,** Warwick  
Tel: +44 (0)1926 317 878  
parker.uk@parker.com

**ZA – South Africa,** Kempton Park  
Tel: +27 (0)11 961 0700  
parker.southafrica@parker.com

## North America

**CA – Canada,** Milton, Ontario  
Tel: +1 905 693 3000

**US – USA,** Cleveland  
Tel: +1 216 896 3000

## Asia Pacific

**AU – Australia,** Castle Hill  
Tel: +61 (0)2-9634 7777

**CN – China,** Shanghai  
Tel: +86 21 2899 5000

**HK – Hong Kong**  
Tel: +852 2428 8008

**IN – India,** Mumbai  
Tel: +91 22 6513 7081-85

**JP – Japan,** Tokyo  
Tel: +81 (0)3 6408 3901

**KR – South Korea,** Seoul  
Tel: +82 2 559 0400

**MY – Malaysia,** Shah Alam  
Tel: +60 3 7849 0800

**NZ – New Zealand,** Mt Wellington  
Tel: +64 9 574 1744

**SG – Singapore**  
Tel: +65 6887 6300

**TH – Thailand,** Bangkok  
Tel: +662 186 7000

**TW – Taiwan,** Taipei  
Tel: +886 2 2298 8987

## South America

**AR – Argentina,** Buenos Aires  
Tel: +54 3327 44 4129

**BR – Brazil,** Sao Jose dos Campos  
Tel: +55 800 727 5374

**CL – Chile,** Santiago  
Tel: +56 2 623 1216

**MX – Mexico,** Toluca  
Tel: +52 72 2275 4200



### EMEA Product Information Centre

Free phone: 00 800 27 27 5374

(from AT, BE, CH, CZ, DE, DK, EE, ES, FI, FR, IE, IL, IS, IT, LU, MT, NL, NO, PL, PT, RU, SE, SK, UK, ZA)

### US Product Information Centre

Toll-free number: 1-800-27 27 537

[www.parker.com/gsf](http://www.parker.com/gsf)